

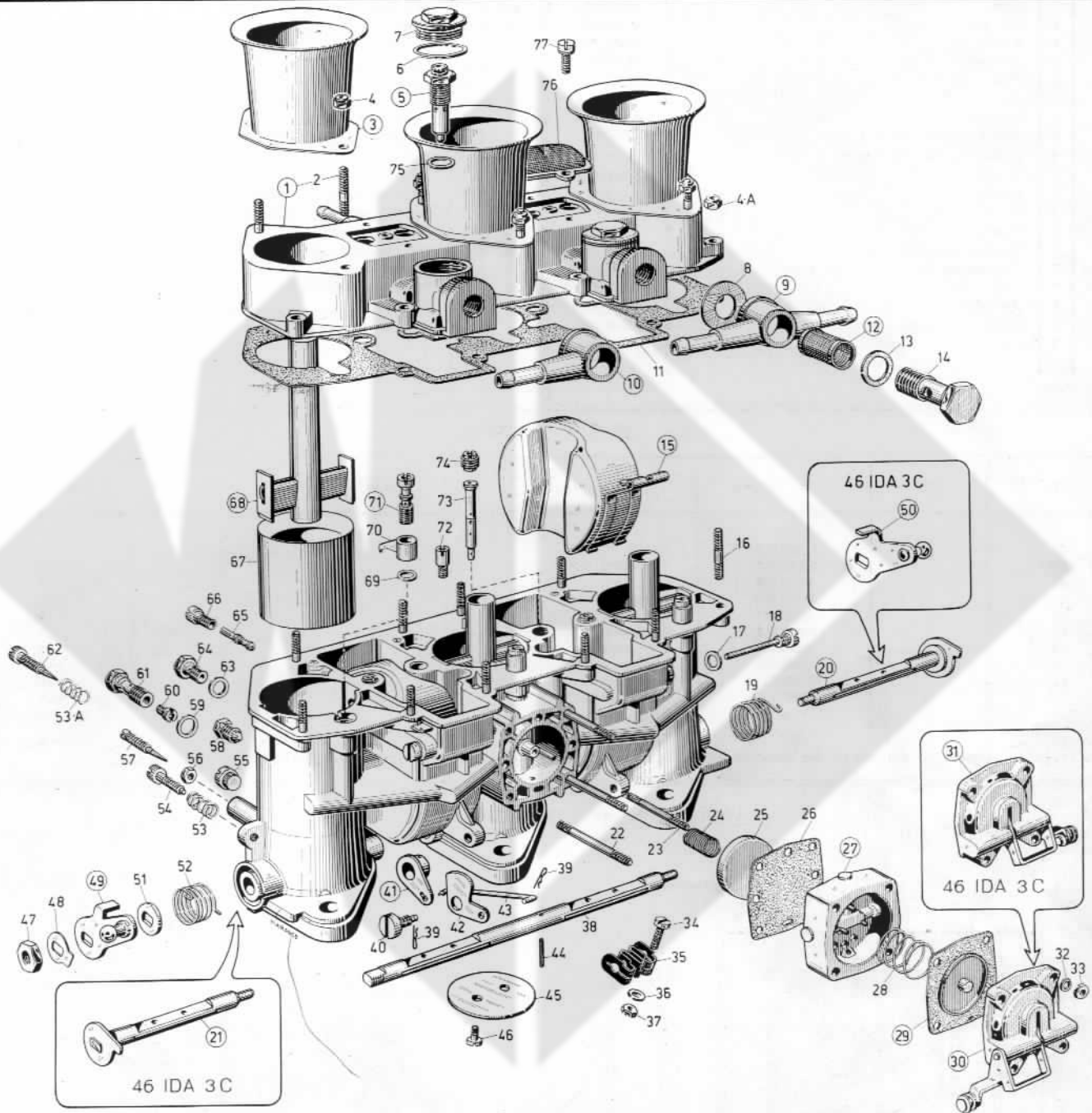

# WEBER CARBURETORS

Type **46 IDA 3C - 3C1**

Application  
**PORSCHE**  
**Carrera 6**



**ORDERS:** When placing orders, always mention reference number of requested parts, as well as type and number of carburetor.

Fig.	Q.ty	PART NAME	Order number	Fig.	Q.ty	PART NAME	Order number
1	1	<b>Carburetor cover</b> including:	31726.001	21	1	<b>Spindle - 46 IDA 3C</b>	10015.457
2	6	— Stud	64955.014	21	1	<b>Spindle oversize - 46 IDA 3C</b>	10016.443
3	3	<b>Air intake</b>	52845.006	22	2	Stud	64955.011
4	6	Nut	34725.003	23	2	Stud	64955.017
4-A	10	Nut	34725.003	24	1	Spring	47600.128
5	2	<b>Needle valve</b>	64240.009 *	25	1	Pump valve	64190.004 *
6	2	Gasket	41530.035	26	1	Diaphragm	47405.011
7	2	Plug	61002.005	27	1	<b>Pump Body</b>	39174.002
8	2	Gasket	41530.004	28	1	Spring	47600.012
9	1	<b>Filter Body</b>	10356.005	29	1	<b>Diaphragm</b>	47407.010
10	1	<b>Filter Body</b>	10356.002	30	1	<b>Pump Cover - 46 IDA 3C1</b>	32486.009
11	1	Gasket	41710.001	31	1	<b>Pump Cover - 46 IDA 3C</b>	32486.010
12	2	<b>Filter Gauze</b>	37022.001	32	4	Spring washer	55525.007
13	2	Gasket	41530.001	33	4	Nut	34705.002
14	2	Plug	12715.014	34	2	Screw	64615.006
15	2	<b>Float</b>	41015.007	35	1	Elastic joint	32270.001
16	10	Stud	64955.012	36	2	Flat washer	55510.038
17	2	Gasket	41530.017	37	2	Nut	34705.002
18	2	Fulcrum screw	64900.012	38	1	Spindle	10005.412
19	1	Spring	47610.072	38	1	<b>Spindle oversize</b>	10006.408
20	1	<b>Spindle - 46 IDA 3C1</b>	10015.458	39	2	Split pin	32610.006
20	1	<b>Spindle oversize - 46 IDA 3C1</b>	10016.442	40	1	Fulcrum screw	64895.002

Fig.	Qty	PART NAME	Order number	Fig.	Qty	PART NAME	Order number
41	1	Lever	45027.007	60	3	Main jet	41120.001*
42	1	Cam	14855.003	61	3	Jet-holder	52590.001
43	1	Tie rod	61280.031	62	3	Idling mixture adjusting screw	64750.001
44	1	Spring pin	58445.001	63	2	Gasket	41530.008
45	3	Throttle	64005.006	64	2	Plug	61002.006
46	6	Screw	64520.027	65	3	Idling jet	41160.003*
47	1	Nut	34715.014	66	3	Jet-holder	52570.005
48	1	Washer	55520.002	67	3	Choke	34894.004*
49	1	Control Lever - 46 IDA 3C1	45034.007	68	3	Secondary Venturi	31966.004*
50	1	Control Lever - 46 IDA 3C	45034.011	69	3	Gasket	41530.012
51	1	Washer	55555.019	70	3	Pump jet	41252.001*
52	1	Spring	47610.071	71	3	Delivery valve	64290.005
53	1	Spring	47600.007	72	1	Intake valve	64290.001*
53-A	3	Spring	47600.007	73	3	Emulsifying tube	61440.213*
54	1	Throttle adjusting screw	64590.002	74	3	Air corrector jet	41360.001*
55	3	Progression hole inspection screw	61015.009	75	2	Gasket	41530.022
56	3	Nut	34705.001	76	2	Filter element	37012.003
57	3	Air adjusting screw	64750.002	77	4	Screw	64700.007
58	3	Choke fixing screw	64840.001				
59	3	Gasket	41540.001				
						Assortment for complete overhaul	IM 831a
						Assortment for normal overhaul	IM 832a
						Gasket Assortment	IM 833a

(\*) Calibrated parts

### SETTING

Fig.	Qty	Order number	PART NAME	Size in mms.
67	3	34894.004	Choke	42
68	3	31966.004	Secondary Venturi	4,50
60	3	41120.001	Main jet	1,70
65	3	41160.003	Idling jet	0,70
70	3	41252.001	Pump jet	0,50
73	3	61440.213	Emulsifying tube	F 24
74	3	41360.001	Air corrector jet	1,45
5	2	64240.009	Needle valve	1,75
72	1	64290.001	Intake valve (with exhaust hole)	0,40
15	2	41015.007	Float (weight)	gms. 25,5
—	—	—	Float levelling	12,5 ÷ 13 (**)

Messrs. E. WEBER do not answer for eventual working anomalies due to arbitrary modifications introduced into the above setting.

### (\*\*) DIRECTIONS FOR LEVELLING THE FLOAT

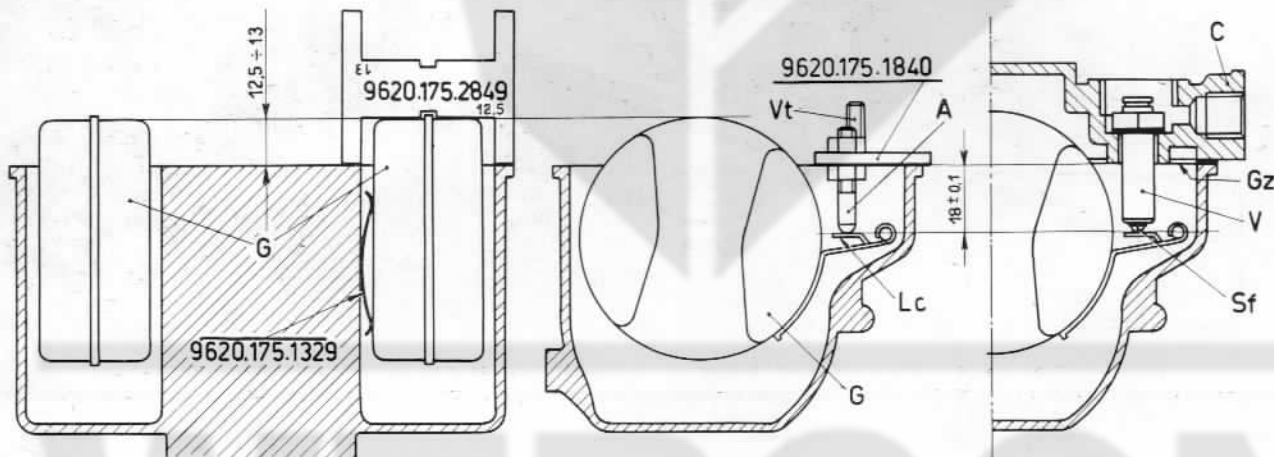

It is essential that the following directions be complied with in order to obtain correct levelling of the float:

- Remove carburetor (C) and take off the gasket (Gz) being careful not to damage the latter; check that the floats (G) slide freely in their housing.
- Insert spring 9620.175.1329 between one float and the wall of the carburetor bowl.
- Insert calibre 9620.175.1840 with control tab (A) 18 mms. long into the two studs (Vt) until it touches the carburetor body surface.
- Raise the float (G) so that the tab (Lc) is placed in light contact with the control tab (A), taking care that the float (G) remains in this position through the pressure of the friction spring.
- Check with calibre 9620.175.2849 that the top of the float is  $12,5 \div 13$  mms. from the surface of the carburetor body; repeat the above operations for the other float also.
- Should the float (G) be incorrectly placed, modify the position of the tabs (Lc) until they are perpendicular to the axis of tab (A) and make sure it does not have any indentations on the contact surface which might affect the free movement of the needles with ball (Sf) of the valves (V).
- Remove the friction spring, fit gasket (Gz) and cover (C), making certain that the needle valve (V) is well screwed down in its housing; then proceed with uniform tightening of the carburetor cover nuts.
- Should it be necessary to replace the needle valves (V), make certain the new valves are well screwed into their relative housings, using new seal gaskets and repeating the levelling operation for each of the floats.

Soc. p. Az. EDOARDO WEBER - Fabbrica Italiana Carburatori

Works: BOLOGNA Via Timavo 33 - Telephone 41.79.95 (Italy) Cable address: WEBER - BOLOGNA - TELEX: 51119 WEBER BO