

-10 100 SERIES - STRAIGHT HOSE END

 **A4**
3RD ANGLE PROJECTION

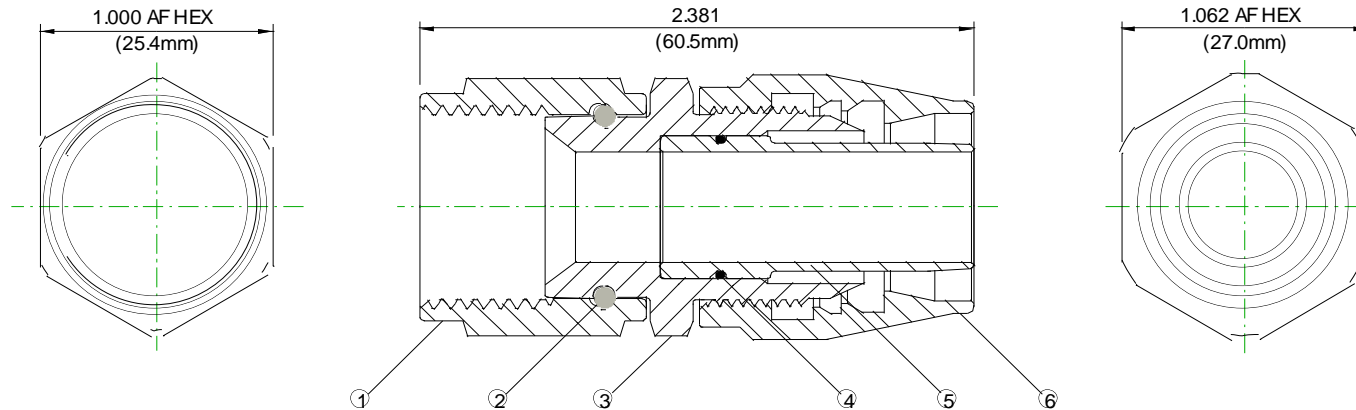

NETWEIGHT OF THIS ASSEMBLY IS 50.0 GRAMS

6	1	C1000-10	SOCKET	AL ALLOY	ANODIZED
5	1	C1020-10	CENTRE NIPPLE	AL ALLOY	HARD COAT ANODIZED
4	1	COM-14	ORING M14 x 1.0	NITRILE	OILED
3	1	C101-10	CENTRE NIPPLE	AL ALLOY	HARD COAT ANODIZED
2	1	CW-W10	WIRE NUT WIRE	St STEEL	POLISHED
1	1	C1001-10	WIRE NUT 7/8" x 14 UNF	AL ALLOY	ANODIZED
MK #	QTY	PART#	DESCRIPTION	MATERIAL	SURFACE CONDITION

SPEED FLOW PRODUCTS PTY LTD

MAX 3D
V14

Drg No: 101-10

Drg Date: 23/02/2013

101-10