

-8 100 SERIES- 60° HOSE END

3RD ANGLE PROJECTION

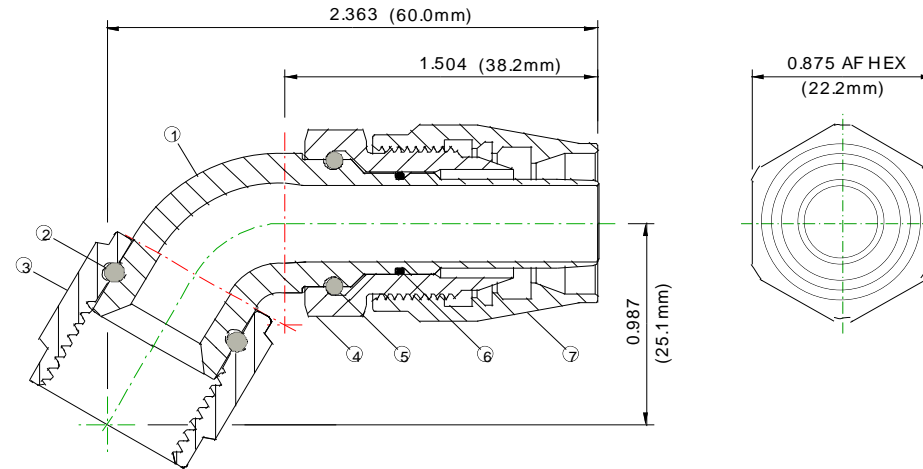

NETWEIGHT OF THIS ASSEMBLY IS 64.0 GRAMS

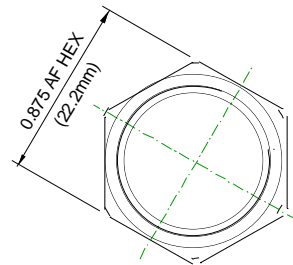

7	1	C1000-08	SOCKET	AL ALLOY	ANODIZED
6	1	COM-11	O RING M11 x 1.0	NITRILE	OILED
5	1	CW-S08	SWIVEL CUTTER WIRE	St STEEL	POLISHED
4	1	C1030-08	SWIVEL CUTTER	AL ALLOY	ANODIZED
3	1	C1001-08	WIRE NUT 3/4" x 16 UNF	AL ALLOY	ANODIZED
2	1	CW-W08	WIRE NUT WIRE	St STEEL	POLISHED
1	1	C102-08	60° CENTRE NIPPLE	AL ALLOY	HARD COAT ANODIZED
MK #	QTY	PART #	DESCRIPTION	MATERIAL	SURFACE CONDITION

SPEED FLOW PRODUCTS PTY LTD

MAX 3D
V14

Drg No: 108-08

Drg Date: 15/03/2013

108-08