

-6 100 SERIES - 30° HOSE END

 **A4**
3RD ANGLE PROJECTION

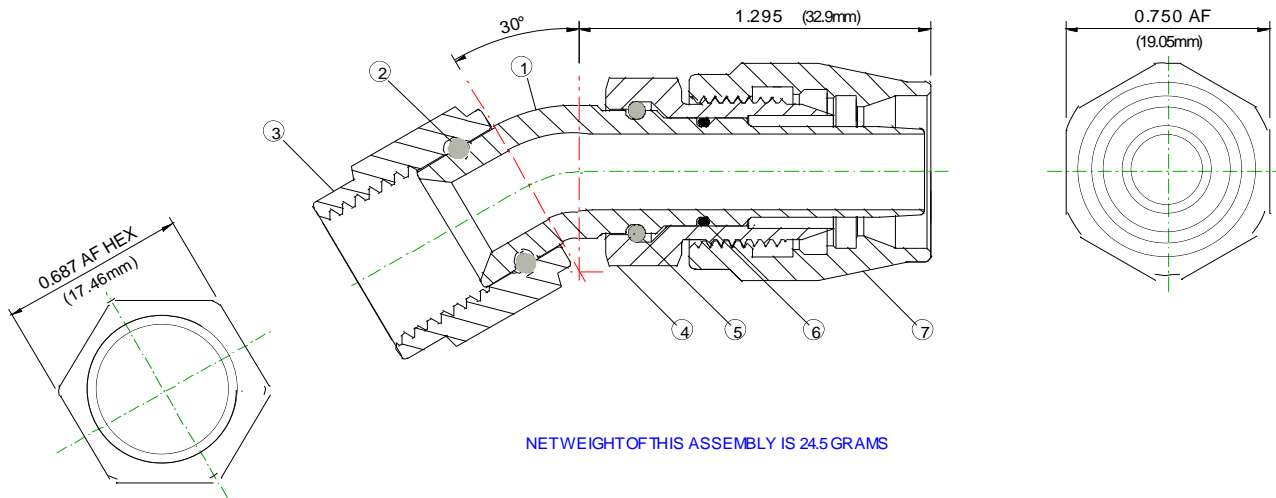

7	1	C1000-06	SOCKET	AL ALLOY	ANODIZED
6	1	COM-08	ORING M8 x 1.0	NITRILE	OILED
5	1	CW-S-06	SWIVEL CUTTER WIRE	St STEEL	POLISHED
4	1	C1030-06	SWIVEL CUTTER	AL ALLOY	ANODIZED
3	1	C1001-06	WIRE NUT 9/16"x18 UNF	AL ALLOY	ANODIZED
2	1	CW-W-06	WIRE NUT WIRE	St STEEL	POLISHED
1	1	C107-06	30° CENTRE NIPPLE	AL ALLOY	HARD COAT ANODIZED
MK#	QTY	PART#	DESCRIPTION	MATERIAL	SURFACE CONDITION

SPEED FLOW PRODUCTS PTY LTD

MAX 3D
V14

Drg No: 107-06

Drg Date: 24/01/2013

107-06