

-6 100 SERIES- 150° HOSE END

3RD ANGLE PROJECTION **A4**

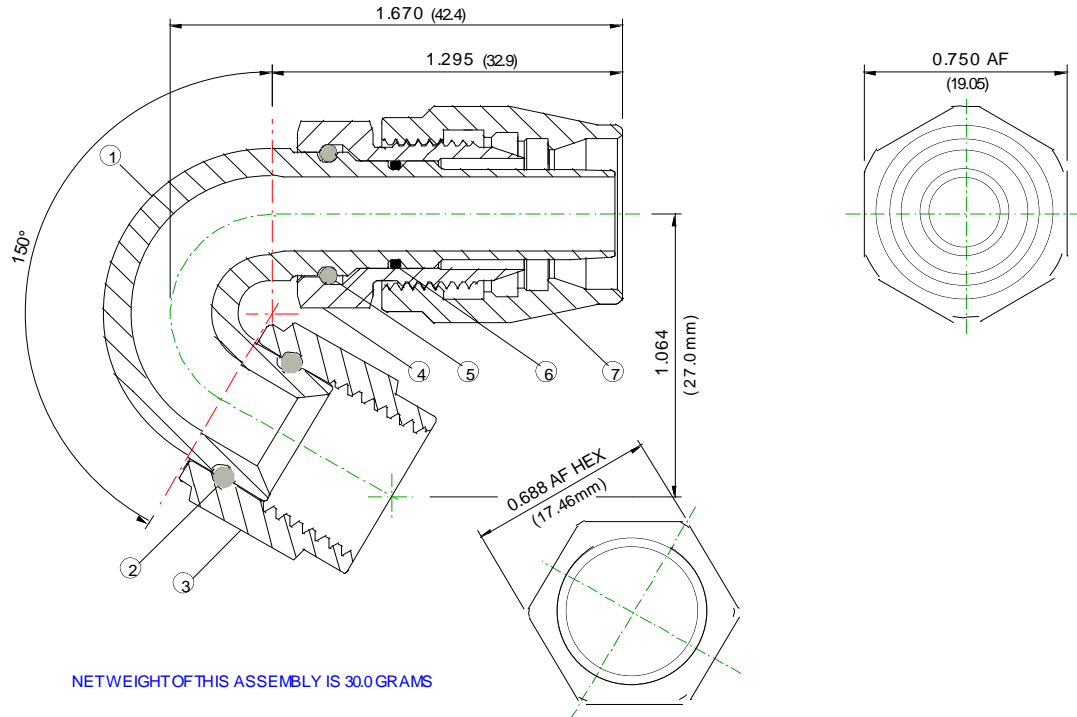

NETWEIGHT OF THIS ASSEMBLY IS 30.0 GRAMS

7	1	C1000-06	SOCKET	AL ALLOY	ANODIZED
6	1	COM-08	O RING M8 x 1.0	NITRILE	OILED
5	1	CW-S06	SWIVEL CUTTER WIRE	St STEEL	POLISHED
4	1	C1030-06	SWIVEL CUTTER	AL ALLOY	ANODIZED
3	1	C1001-06	WIRE NUT 9/16"x18 UNF	AL ALLOY	ANODIZED
2	1	CW-W06	WIRE NUT WIRE	St STEEL	POLISHED
1	1	C105-06	150° CENTRE NIPPLE	AL ALLOY	HARD COAT ANODIZED
MK #	QTY	PART #	DESCRIPTION	MATERIAL	SURFACE CONDITION

SPEED FLOW PRODUCTS PTY LTD

MAX 3D
V14

Drg No: 105-06

Drg Date: 24/01/2013

105-06