

SPECIAL NUTS, STUDS AND BOLTS FOR WHEELS



We offer specialty wheel studs and bolts manufactured from high tensile steel which undergo a thread rolling process to reduce the risk of fatigue related failures.

Knowledge from our competition experience has led us to use a dissimilar material for the nut from that for the wheel stud. The additional copper coating of the nut assures security.

The latest addition to our range is the competition quality special aluminum wheel nut manufactured in Ergal 7075.

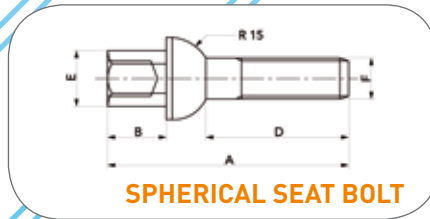
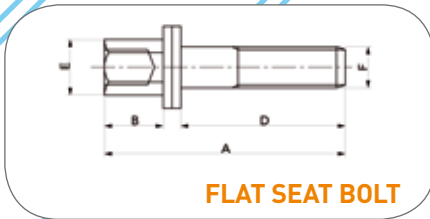
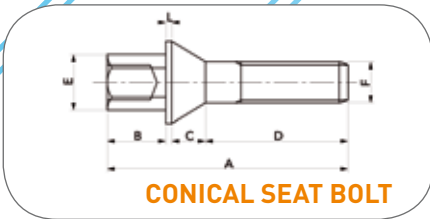
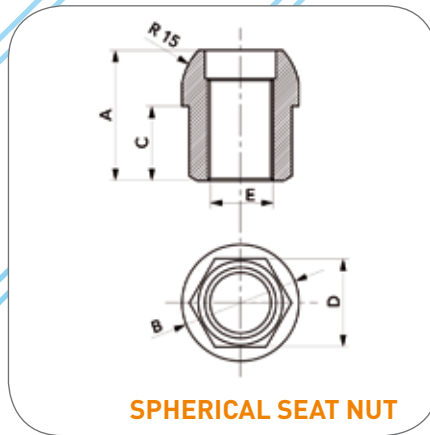
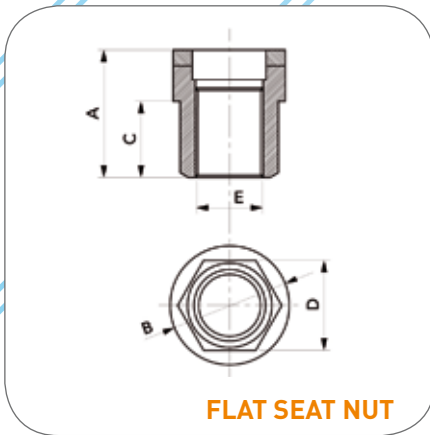
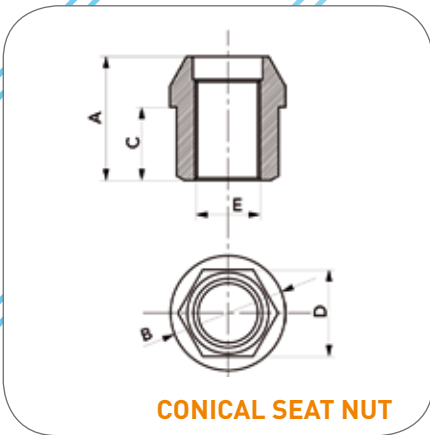
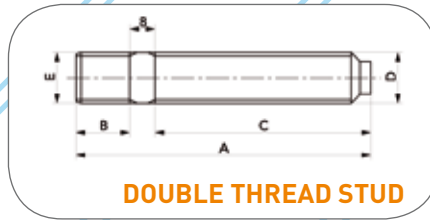
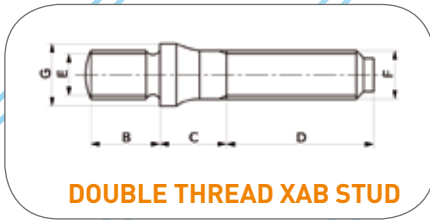
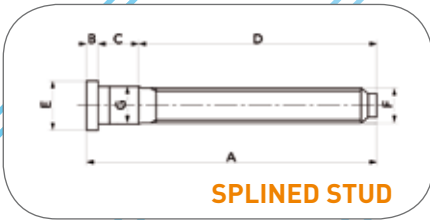

Datasheet for special nuts, studs and bolts for wheels

SPLINED STUD

Ref.	A	B	C	D	E	F	G	Application
AIT-68C	68	4	14	50	17	12 x 1,5	12,8	Ford
AIT-82C	82	4	14	64	17	12 x 1,5	12,8	Ford
AIT-100C	100	4	14	82	17	12 x 1,5	12,8	Ford
AIT-65CH	65	4	15	45	20	1/2" UNF	15,7	Chrysler
AIT-68CH	68	4	7	57	20	12 x 1,5	14,9	Chrysler
AIT-75G	75	4	11	59,5	20	14 x 1,5	14,3	Porsche
AIT-100G	100	5	13	82	20	14 x 1,5	14,8	Porsche
AIT-64HY	64	4	10	50	17	12 x 1,5	14,4	Hyundai
AIT-68H	68	5	11	52	19	12 x 1,5	12,3	Honda
AIT-61M	61	4	8	42	20	12 x 1,5	14,7	Mazda
AIT-65M	65	4	11	50	17	12 x 1,5	13	Mazda
AIT-67MIT	67	3	7	57	18	12 x 1,5	14,2	Mitsubishi
AIT-62N	62	5	7	50	20	12 x 1,25	14,2	Nissan
AIT-64N	64	4	10	50	19	12 x 1,25	12,8	Nissan
AIT-60R	60	4	11	45	18	12 x 1,5	12,3	Rover
AIT-66S	66	5	10	51	19	12 x 1,25	14,2	Subaru
AIT-68STR	68	9	15	51	24	14 x 1,5	16,9	Lancia Stratos
AIT-73T	73	5	9	59	18	12 x 1,5	14,3	Toyota
AIT-69V	69	4	10	55	18	12 x 1,5	12,4	Volvo
AIT-70V	70	5	17	48	21	12 x 1,5	16,3	Volvo
AIT-72J	72	5	10	57	18	1/2" UNF	13,7	Jaguar/Aston Martin
AIT-59D	59	3	10	46	19	12 x 1,25	12,4	Daewoo/Matiz
AIT-70AR	70	5	10	55	20	12 x 1,5	13,8	Alfa Romeo (old style)
AIT-74V	74	4	13	57	18	12 x 1,5	13,5	Volvo
AIT-81AR	81	5	19	57	22 x 19	12 x 1,5	12	Alfa Romeo (old style)
AIT-84J	84	5	7	72	17	1/2" UNF	13,4	Jaguar
AIT-55F	55	5	15	35	20	14 x 1,5	14,9	VW/ Audi/Porsche
AIT-74NSR	74	6	14	54	24	5/8"	17,5	Nascar
AIT-108NSR	108	6	14	88	24	5/8"	17,5	Nascar

CONICAL SEAT NUT

Ref.	A	B	C	D	E	Application
AIT-DADO	25	23	14	19	12 x 1,25	Universal application
AIT-DADO1	25	23	14	19	12 x 1,5	Universal application
AIT-DADO2	28	28	13	19	12 x 1,5	Ford Motorsport
AIT-DADO4	27	25	16	22	14 x 1,5	Gr. A/WRC/VW
AIT-DADO6	27	25	16	19	14 x 1,5	Gr. A/WRC/VW
AIT-DADO9	27	25	15	17	12 x 1,25	Universal application
AIT-DADO10	33	23	23	19	12 x 1,5	Mitsubishi
AIT-DADO12	28,5	28	16	19	12 x 1,5	Opel
AIT-DADO15	27	25	16	3/4"	1/2 UNF	Jaguar/Usa
AIT-DADO18	25	23	15,5	17	12 x 1,5	Opel
AIT-DAAL	27	22	19	19	12 x 1,25	Universal application
AIT-DAAL1	27	22	19	19	12 x 1,5	Universal application
AIT-DAAL2	34	22	20	19	12 x 1,25	Universal application
AIT-DAAL3	34	22	20	19	12 x 1,5	Ford/Universal appl.
AIT-DAAL6	27	25	16	19	14 x 1,5	VW/Porsche
AIT-DAAL11	28	28	13	19	12 x 1,5	Ford Motorsport
AIT-DAAL15	27	25	16	3/4"	1/2 UNF	Jaguar/Usa

FLAT SEAT NUT

Ref.	A	B	C	D	E	Application
AIT-DADO3	29	28	21	19	12 x 1,25	Peugeot/Citroen

SPHERICAL SEAT NUT

Ref.	A	B	C	D	E	Application
AIT-DADO5	28	25	17	19	14 x 1,5	VW/Audi
AIT-DADO7	28	25	17	17	12 x 1,25	Renault
AIT-DADO8	27	25	15	17	12 x 1,25	Universal application
AIT-DADO19	27	25	17,5	17	12 x 1,5	Opel/Universal appl.
AIT-DAAL8	31	25	20	19	14 x 1,5	VW -Porsche

Note: The Ergal nuts (DAAL) are available a stock only black colour, six colours choices to order (minimum order 300 pieces).

AIT-DADO= STEEL MADE
AIT-DAAL= ALUMINIUM MADE

DOUBLE THREAD XAB STUD (reinforced root)

Ref.	A	B	C	D	E	F	G	Application
AIT-70XA	70	13	12	45	12 x 1,25	12 x 1,25	18 x 15	Universal application
AIT-70XB	70	13	12	45	12 x 1,5	12 x 1,25	18 x 15	Universal application
AIT-84XA	84	13	12	59	12 x 1,25	12 x 1,25	18 x 15	Universal application
AIT-84XB	84	13	12	59	12 x 1,5	12 x 1,25	18 x 15	Universal application
AIT-90XD	90	15	12	63	1/2" UNF	1/2" UNF	18 x 9/16"	Universal application

DOUBLE THREAD STUD (for universal applications)

Ref.	A	B	C	D	E	Application
AIT-68A	68	15	46	12 x 1,25	12 x 1,25	Universal application
AIT-82A	82	15	59	12 x 1,25	12 x 1,25	Universal application
AIT-100A	100	15	77	12 x 1,25	12 x 1,25	Universal application
AIT-68B	68	15	46	12 x 1,25	12 x 1,5	Universal application
AIT-82B	82	15	59	12 x 1,25	12 x 1,5	Universal application
AIT-100B	100	15	77	12 x 1,25	12 x 1,5	Universal application
AIT-68F	68	15	46	14 x 1,5	14 x 1,5	VW/Audi
AIT-82F	82	15	59	14 x 1,5	14 x 1,5	VW/Audi
AIT-100F	100	15	77	14 x 1,5	14 x 1,5	VW/Audi
AIT-700P	70	15	47	12 x 1,5	12 x 1,5	Opel
AIT-900P	90	15	67	12 x 1,5	12 x 1,5	Opel
AIT-1000P	100	15	77	12 x 1,5	12 x 1,5	Opel
AIT-71M	71	15	48	14 x 1,5	14 x 1,25	Bmw Mini 06/07
AIT-80M	80	15	57	14 x 1,5	14 x 1,25	Bmw Mini 06/07
AIT-65PC	65	15	43	14 x 1,5	14 x 1,5	Porsche Cayman

CONICAL SEAT BOLT

Ref.	A	B	D	E	F
AIT-BA75	75	14	48	19	12 x 1,25
AIT-BB75	75	14	48	19	12 x 1,5
AIT-BL75	75	14	48	17	14 x 1,5
AIT-BH75	75	14	46	19	12 x 1,75
AIT-BG75	75	14	48	17	12 x 1,5

FLAT SEAT BOLT

Ref.	A	B	D	E	F
AIT-BP80	80	20	54	19	12 x 1,25

SPHERICAL SEAT BOLT

Ref.	A	B	D	E	F
AIT-BF75	75	14	54	19	14 x 1,5
AIT-BM75	75	14	74	17	12 x 1,5
AIT-BM85	85	14	64	17	12 x 1,5